



Traffic Safety Corporation  
 2708 47th Ave.  
 Sacramento, CA 95822-3806  
 Toll Free: 888.446.9255  
 Tel: 916.394.9884  
 Fax: 916.394.2809  
 Email: sales@xwalk.com  
 Web: www.xwalk.com

**TS-400**  
**Self-Cleaning, Bi-Directional Fixture**  
**In-Roadway Warning Lighting Systems**

**General Description**

The TS-400 fixture is designed as a cost effective solution for In-Roadway Warning Lighting Systems where snowplows are not employed. The TS-400's outstanding durability and low maintenance design makes it ideal for applications where after installation costs must be minimized. The use of Highbright LED energy efficient technology provides superior visibility and energy efficiency, making the TS-400 ideal for solar power applications. The Bi-directional design of the TS-400 allows backlighting of pedestrians in the crosswalk, further improving pedestrian safety.

The TS-400 is typically used in crosswalk applications, but is often used in school zone or railroad crossing, lane control for bridges and tunnels, wrong way warning, and toll booth or toll way lead-on applications.

All In-Roadway Warning Lighting System components are available from TSC. A typical installation would include a set of fixtures, a control system, one or more activation devices such as a pedestrian push button station or pedestrian detection pad, and flashing LED crossing signs.

**Why Our TS-400 Is Better**

**Outstanding Durability**

- Corrosion resistant anodized aluminum body stands up to traffic wear and weather.
- High static load rating (44,000 lb.) reduces likelihood of damage from heavy vehicles.

**Superior Visibility and Energy Efficiency**

- Bi-directional design improves visibility of pedestrians in crosswalk.
- Highbright LEDs produce a brightness level of over 600,000 candela per meter squared making them clearly visible in daytime and under the worst weather conditions.
- Highbright 12 Volt LEDs consume only 3 watts/fixture making them ideal for energy efficient solar power applications.



**Low Maintenance**

- Re-usable design reduces the cost, effort and time during resurfacing of the road.
- Self-cleaning lens design reduces build-up of dirt and need for frequent cleaning.
- Pressurized light cavity keeps moisture out and reduces the frequency of replacement.
- Pre-focused optics eliminates the requirement of field adjustments.
- Long life LEDs (Average rated life of 10 years) reduces frequency of replacement.

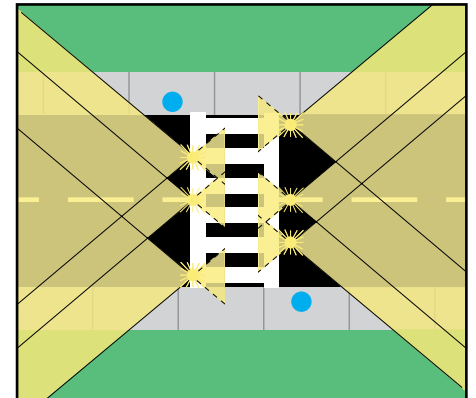

*Application: Two Way,  
One Lane Each Way*

**Ordering Codes**

Fixture	Directional	Beam	LED Color	Lamp	Options
TS-400	BI	Narrow/Narrow	___ / ___	L: 12V LED Array	D: Dimming
TS-420	BI	Wide/Wide	___ / ___		
TS-450	BI	Wide/Narrow	___ / ___		
TS-401	UNI	Narrow	___		
TS-421	UNI	Wide	___		

Notes: 1. LED Color: Y = Yellow, R = Red, X = Blank (Specify both lens).  
 2. Standard fixture operating voltage is 12 VDC. Fixtures may also be operated from 24 VDC in certain applications. Operation at 24 VDC requires driver modification.  
 3. The self-cleaning feature will be effective only if fixture is installed on level ground.  
 4. TSC supports legacy fixtures with Halogen LA-008084 (Special Order).  
 5. Base Cans (BA-725-5-2), Base Can Extensions (BA-725-EX-XX), Spacers (BA-725-SP-XX) and Gaskets (BA-725-GSK) are available for the TS-400 Fixture.  
 6. Power consumption is 3 watts per fixture.  
 7. Female Connector (CO-1051903021) is available for power source hook-up.  
 8. Fixture repair package available (LA-008114-KIT) includes LED Array, LED Driver, and Gaskets, plus factory installation, testing and burn-in.  
 9. Dimming option will only work with the TSI200 and TSI250 controllers.

**Visit our web site: [www.xwalk.com](http://www.xwalk.com)**



**Traffic Safety Corporation**  
 2708 47th Ave.  
 Sacramento, CA 95822-3806  
 Toll Free: 888.446.9255  
 Tel: 916.394.9884  
 Fax: 916.394.2809  
 Email: sales@xwalk.com  
 Web: www.xwalk.com

**TS-400**

## Self-Cleaning, Bi-Directional Fixture In-Roadway Warning Lighting Systems

### How to Specify the TS-400 Family of Self-Cleaning Bi-Directional Fixtures

The fixture shall be model TS-4xx-YYL1/YXL1 as marketed by Traffic Safety Corporation or approved equal. In order to be considered equal, the alternate fixture shall satisfy the following requirements.

**Construction** – The fixture shall have bi-directional and uni-directional capability, have a modular design comprised of 6 major parts with the top and bottom castings of high tensile strength aluminum alloy. The top and bottom casting shall be sealed by means of a flat gasket. The fixture shall have a smooth shaped face projecting not more than 0.64" when installed in the factory provided mounting base. The fixture shall incorporate a self-cleaning design with an outward sloping light channel to promote drainage and facilitate maintenance. Diameter shall not exceed 8" and all mounting hardware shall be stainless steel. Fixture will operate on 12 VDC and be furnished pre-wired with a waterproof 90P plug.

**Durability** – Fixture shall withstand a static load of 44,000 lb. without sustaining permanent deformation or cracking of materials. Leads, gaskets, etc. shall be rated to withstand 300 degrees F.

**LED/Light Cavity** – The fixture's light beam shall be refractor controlled and pre-focused to simplify maintenance. The refractors shall be molded high performance optical grade glass and formed to provide a sealed fit within the fixture. High density silicone rubber gaskets shall be used to provide a proper seal. There will be two hardened glass refractors per fixture, one aimed at 0 degrees and the other aimed at 180 degrees, to be installed parallel to roadway center line. To prevent moisture intrusion, each fixture shall be installed with a Schrader valve to facilitate verification that the entire assembly is sealed at the time of installation and to allow for re-testing during maintenance. Two refractor beam spread options shall be provided – 60 degrees and 10 degrees, as well as the capability to operate in a uni-directional mode through the use of a blank plate. The glass refractor pointed towards the inside of the crosswalk shall normally have a beam angle of 60 degrees. To facilitate early onset of the driver's awareness of the crosswalk, the outboard facing refractors shall normally have beam angle of 10 degrees, except on curves where a 60 degree beam may be more desirable. In some cases it may be desirable to utilize the fixture in a uni-directional mode and a blank may be inserted in place of one of the refractors.

**Photometric Performance** – The fixture shall be clearly visible in any weather condition, daytime and at night, and shall produce a yellow light using a 12 Volt, 3 watt LED array with a brightness level of more than 600,000 candela per meter squared using the 10 degree refractor option.

**Finish** – The top cover shall be natural anodized aluminum, grey in color. The bottom cover shall have a black powder coat.

**Mounting Base** – Fixture shall be installed in mounting base (TSC #BA-725-5-2MR) of high strength steel, hot dip galvanized after fabrication per ASTM-153 specifications, with a 7.25" diameter bolt circle, a 0.75" mud ring, and standard base depth of 5". The mud ring shall be detachable from the base. Mounting base without mud ring shall be made available upon request. The base shall be supplied with a plywood cover to protect the mounting flange during installation.

**Warranty** - Fixture shall be warranted by the manufacturer against defects in materials and workmanship for one year from date of shipment and is eligible for TSC's 5-Year Limited System Warranty.

### Replacement Parts

- |   |                   |
|---|-------------------|
| 1. Body casting                         |                   |
| 2. Prism clamp                          | 80-021380         |
| 3. Prism clamp gasket                   | 80-033072         |
| 4. Prism gasket (2)                     | 80-033071         |
| 5. Glass prism (1 or 2 Narrow), LED     | 80-016078         |
| Blanking prism (optional)               | 80-040102         |
| Color filters (not shown): yellow       | 80-019157         |
| 6A. 12V LED High Bright                 | LA-008114         |
| 6B. LED Driver                          | 27-TLM4036DC-700  |
| 9. Bottom cover                         | 80-040101         |
| 10. Bottom cover gasket                 | 80-033080         |
| 11. Fixture lead, male                  | TRC-10518-114-D02 |
| 12. Cable gland assembly                | 80-021114/5/6     |
| 13. Schrader (bicycle) valve            | 80-021327         |
| <b>Legacy Halogen Parts (not shown)</b> |                   |
| 50W 120V Halogen                        | LA-008084         |
| Glass prism (1 or 2 Wide), Halogen      | 80-016072         |
| Lamp gasket                             | 80-033077         |
| Lamp retaining spring                   | 80-032039         |

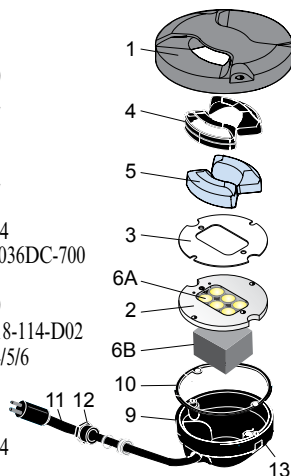

### 60° Wide Beam Light Illumination Pattern

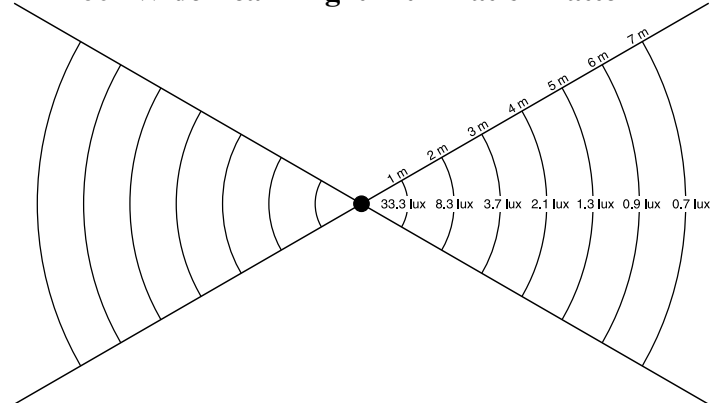

### 10° Narrow Beam Light Illumination Pattern

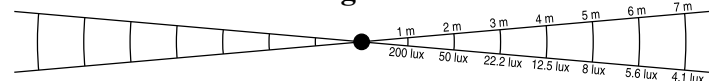

Visit our web site: [www.xwalk.com](http://www.xwalk.com)



**Traffic Safety Corporation**  
 2708 47th Ave.  
 Sacramento, CA 95822-3806  
 Toll Free: 888.446.9255  
 Tel: 916.394.9884  
 Fax: 916.394.2809  
 Email: sales@xwalk.com  
 Web: www.xwalk.com

**TS-400**  
**Self-Cleaning, Bi-Directional Fixture**  
**In-Roadway Warning Lighting Systems**

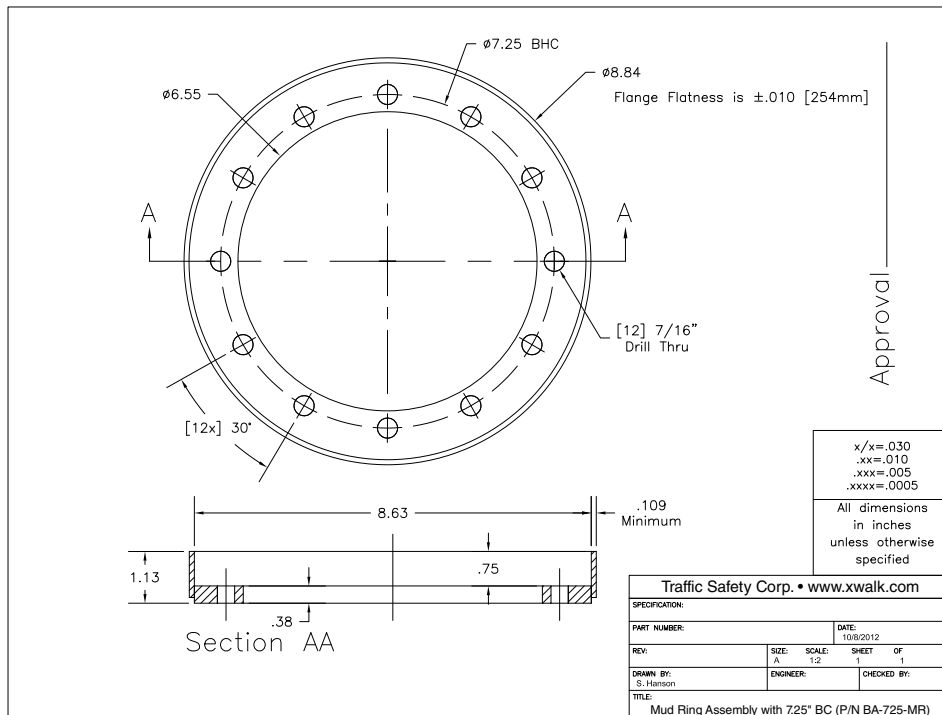
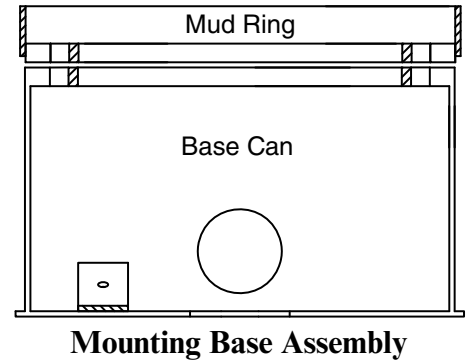
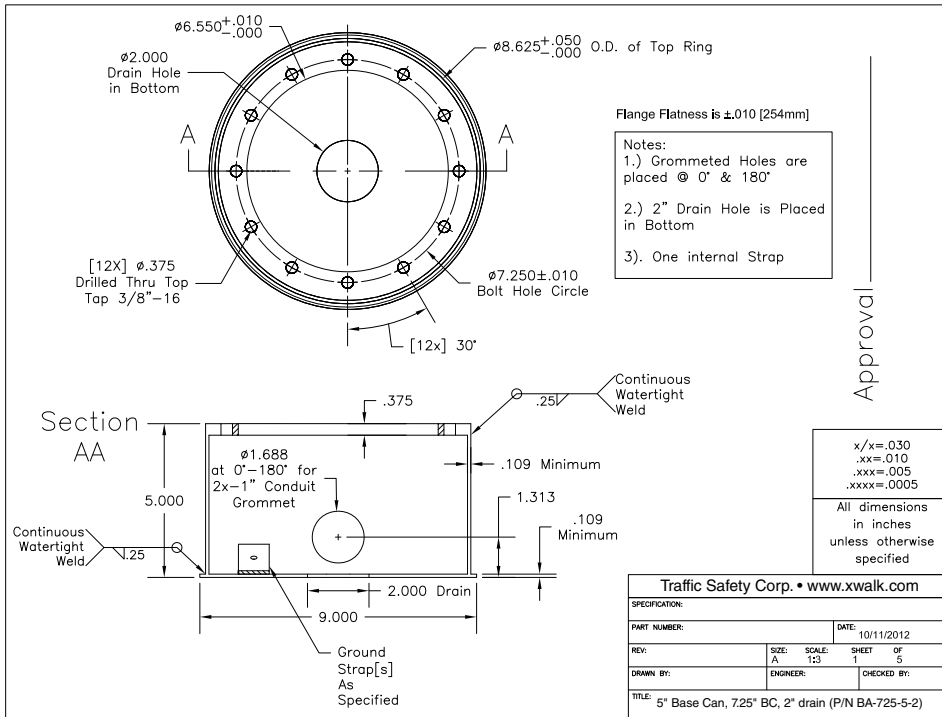

**Visit our web site: [www.xwalk.com](http://www.xwalk.com)**